

Hydraulic Body Repair Set

9TY120

- The separable hydraulic jack is a new multipurpose tool which composed by hydraulic pump and jack
- Featured by compact structure, simple convenient and safe operation, quick assembling and disassembling
- It can work for track lifting, jacking, straightening, bending, pressure test, etc
- It is applicable to factories, airports, oilfields, ships, docks, warehouses, railway buildings, scientific research, rescue and relief work, etc

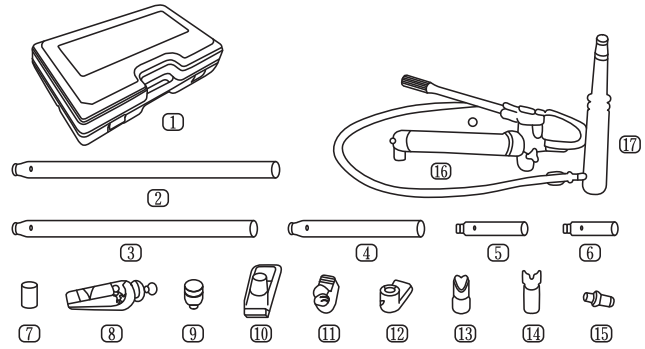
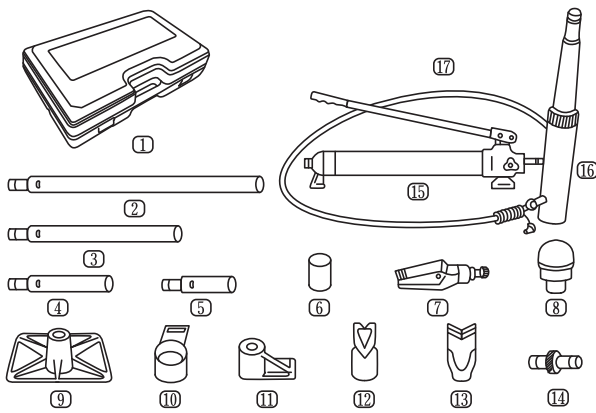

9TY120-10A-B
Key NO.

Part NO.	Description
1	Blow case
2	685mm Extension bar
3	456mm Extension bar
4	250mm Extension bar
5	127mm Extension bar
6	Serrated cap
7	Spreading wedge
8	Big rubber head
9	Base plate
10	Ram toe
11	Plunger toe
12	Cleft cap
13	'V' base
14	Male connector
15	10Ton pump unit
16	Ram unit
17	Hydraulic hose

9TY120-040A-B
Key NO.

Part NO.	Description
1	Blow case
2	495mm Extension bar
3	418mm Extension bar
4	215mm Extension bar
5	125mm Extension bar
6	82mm Extension bar
7	Serrated cap
8	Spreading wedge
9	Rubber head
10	Base plate
11	Ram toe
12	Plunger toe
13	Cleft cap
14	v base
15	Male connector
16	4 Ton pump unit
17	Ram unit
18	Hydraulic hose

KT NO.	Capacity (Ton)	Min. ram height (mm)	Ram lifting height (mm)	N.W (kg)	G.W (kg)	CUFT	
9TY120-040A-B	4	330	120	17	20	1.28 (Blow case)	1/1
9TY120-10A-B	10	470	150	31	36	2.24 (Blow case)	1/1