

Bottle Jack

9TY112

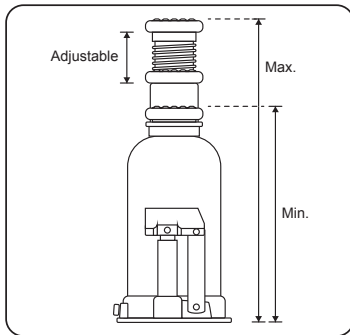

KT NO.	Capacity (T)	Adjustable height (mm)	Min height (mm)	Max height (mm)	N.W (kg)	G.W (kg)	CUFT	
9TY112-02A-B	2	48	175	339	12.48	13.08	0.59	1/6
9TY112-03A-B	3	60	190	368	16.92	17.82	0.79	1/6
9TY112-04A-B	4	60	190	368	16.92	17.82	0.79	1/6
9TY112-05A-B	5	70	210	407	14.88	15.68	0.67	1/4
9TY112-06A-B	6	70	210	407	14.88	15.68	0.67	1/4
9TY112-08A-B	8	80	225	440	18.80	19.36	0.74	1/4
9TY112-10A-B	10	80	225	440	18.80	19.36	0.74	1/4
9TY112-12A-B	12	80	230	465	18.80	18.36	0.64	1/3
9TY112-15A-B	15	80	230	460	13.88	14.14	0.51	1/2
9TY112-16A-B	16	80	230	460	13.88	14.14	0.51	1/2
9TY112-20A-B	20	60	240	450	17.56	17.96	0.57	1/2
9TY112-32A-B	32	-	260	430	17.80	18.05	0.47	1/1
9TY112-50A-B	50	-	280	470	25.80	26.05	0.59	1/1

Bottle Jack

9TY112A

- With blow case

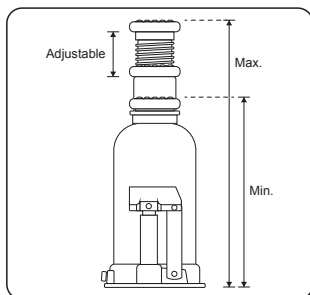

KT NO.	Capacity (T)	Adjustable height (mm)	Min height (mm)	Max height (mm)	N.W (kg)	G.W (kg)	CUFT	
9TY112A-02A-B	2	48	175	339	12.48	14.64	1.18	1/6
9TY112A-03A-B	3	60	190	368	16.92	19.44	1.44	1/6
9TY112A-04A-B	4	60	190	368	16.92	19.44	1.44	1/6
9TY112A-05A-B	5	70	210	407	14.88	17.28	0.93	1/4
9TY112A-06A-B	6	70	210	407	14.88	17.28	0.93	1/4
9TY112A-12A-B	8	80	225	440	18.00	20.52	0.90	1/3