

FORD

EcoBoost 1.0 Timing Set



9AT1026E

- Engine Timing Tool Kit suitable for 1.0 petrol EcoBoost and 1.0 SCTi EcoBoost FORD engines.
- Contains tools vital for setting and locking the engine and for setting the position of the variable cam timing units.

16
PC.



4.4 kg / 1 / 4

MODEL: Fiesta (2013-2016), EcoSport (2013-2015), B-Max (2013-2016), C-Max (2012-2016), Transit Courier (2012-2016), Transit Connect (2013-2016), Focus (2012-2016), Grand Tourneo Connect (2013-2015), Grand C-Max (2012-2016), Mondeo (2015-2016), Tourneo Connect (2013-2015)

ENGINE : MICA, M1CB, M1DA, M1DD, M1JA, M1JC, M1JE, M1JH, M2DA, M2DB, M2DC, M2GA, P4JC, P4JD, SFCA, SFCB, SFDB, SFJA, SFJB, SFJC, SFJD, P4JA, P4JB, XMJA, XMJB, M1JA

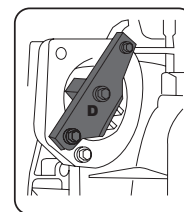
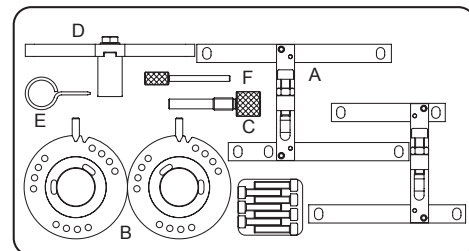

CONTENTS:

- A - Camshaft Locking Tool Set
- B - Camshaft VVT Adjustment Tool Set
- C - Crankshaft Setting Pin
- D - Flywheel Locking Tool
- E - Tensioner Locking Pin
- F - Crankshaft Pulley Positioning Pin

- Remove the starter motor and fit component D in the starter aperture so that its tooth locks the flywheel

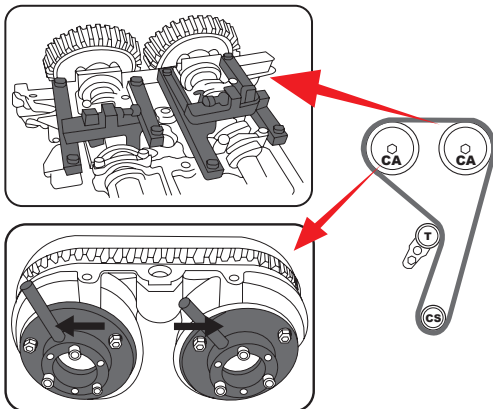

FORD

Petrol Engine Twin Camshaft & Diesel Engine Timing Tool Set



9AT1406E

- The set includes VCT setting plate, camshaft setting plate, crankshaft TDC location pin, tensioner locking pin and flywheel locking tools
- Suitable for 16v. Duratec petrol engine of FORD 1.6 Ti-VCT twin camshaft
- Use to adjust VCT timing on inlet and exhaust camshaft during timing belt replacement



7
PC.

1640 kg / 1 / 10

MODEL: Focus C-Max (03-08)
Focus (04-08)
Mondeo (07-08)

ENGINE CODE: HXDA

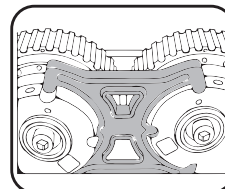
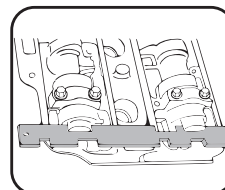

CONTENTS :

- A&E - flywheel locking tool
- B - camshaft setting plate
- C - crankshaft TDC location pin
- D - tensioner locking pin
- F - VCT setting plate
- G - crankshaft pulley alignment tool