

Insert Tool

345022

• Chrome plated

▪ Square drive size : 14 x 18

KT NO.	Size mm	Maximum Torque N·m	Lw* mm	L mm		
34502213M	13	108	25	62.2	129	12 / 192
34502214M	14	128	25	63.2	128	12 / 192
34502215M	15	152	25	63.3	125	12 / 192
34502216M	16	175	25	63.1	137	12 / 192
34502217M	17	202	25	65.0	134	12 / 192
34502218M	18	230	25	65.0	134	10 / 160
34502219M	19	262	25	66.7	135	10 / 160
34502221M	21	330	25	67.3	151	10 / 160
34502222M	22	368	25	68.5	156	6 / 96
34502224M	24	452	25	69.9	156	6 / 96
34502227M	27	595	31	78.0	201	6 / 96
34502230M	30	762	31	79.6	198	6 / 96
34502232M	32	800	31	81.0	201	6 / 96
34502234M	34	800	31	82.4	225	6 / 90
34502236M	36	800	31	83.7	230	6 / 90
34502241M	41	800	31	86.6	235	6 / 90

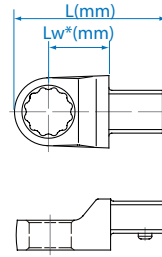

KT NO.	Size inch	Maximum Torque N·m	Lw* mm	L mm		
34502216S	1/2	108	25	62.2	128	12 / 192
34502218S	9/16	128	25	63.2	128	12 / 192
34502220S	5/8	175	25	63.1	132	12 / 192
34502224S	3/4	262	25	66.7	141	10 / 160

34505102R

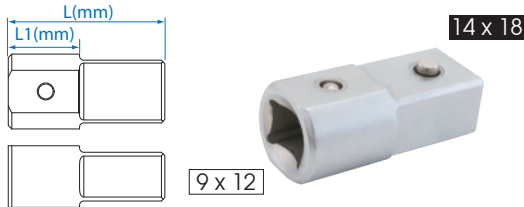

KT NO.			L1 mm	L mm		
34505102R	9 x 12	14 x 18	20.5	45.5	82.2	12 / 144

34505201R

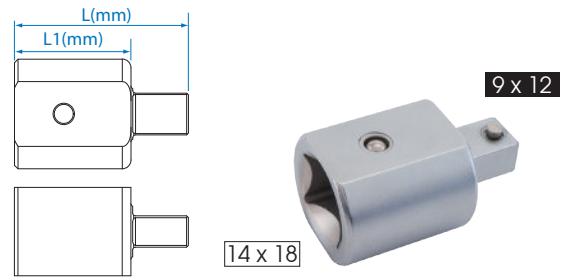

KT NO.			L1 mm	L mm		
34505201R	14 x 18	9 x 12	33.5	49.5	131.8	12 / 144

Hook Wrench Head & Set

345042M

▪ Square drive size: 14 x 18

KT NO.	Size mm	Capacity mm	Maximum Torque N·m	Lw* mm	L mm		
34504236M	36	28-36	354	77	121	248.20	12 / 72
34504245M	45	40-45	377	77	129	274.00	12 / 72
34504255M	55	50-55	398	77	129	263.20	12 / 72
34504262M	62	58-62	421	77	134	278.20	12 / 72
34504275M	75	68-75	444	77	139	294.60	12 / 72
34504290M	90	80-90	465	77	142	288.80	12 / 72

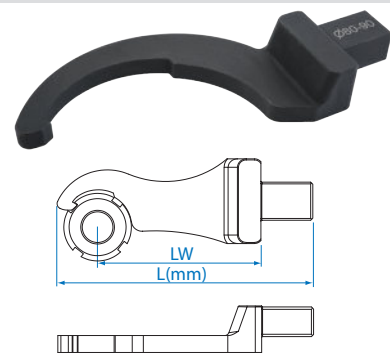

3452407MR

- Suitable for tightening round nuts with radial notches
- Applied with interchangeable torque wrench
- Widely used in automobile, machine tool building and petroleum industries

Contents 2.48 1 / 6

	34505201R	14 x 18(F) → 9 x 12(M)
	345042M	36, 45, 55, 62, 75, 90

