

# Flare Nut Wrench & Set

KT No. & D1



## 1931

- 12 points
- 12° ring offset
- Chrome vanadium alloy steel
- Chrome plated
- DIN 3118

KT NO.	Size mm	L mm		
19312224	22 x 24	250	309	6 / 72
19312427	24 x 27	270	406	6 / 48
19313032	30 x 32	290	546	5 / 40

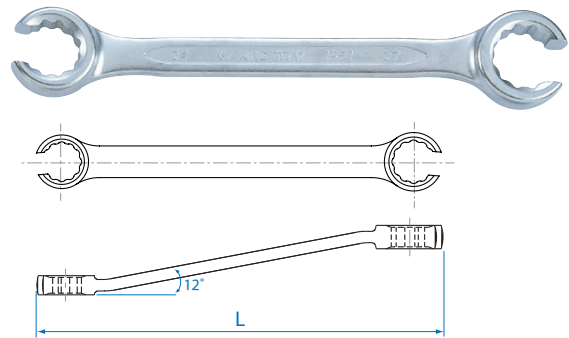

# Flexible Head Wrench & Set

## 1020

- Combination flexible head wrench with 12 points thin wall socket
- 180° swivel head for better accessibility
- Chrome vanadium alloy steel
- Chrome plated

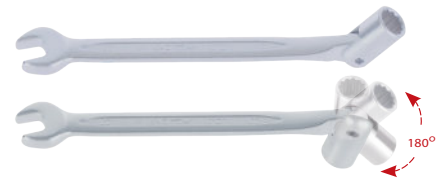

KT NO.	Size mm	L mm		
1020-08	8	170	64	10 / 180
1020-09	9	170	68	10 / 180
1020-10	10	180	81	10 / 160
1020-11	11	188	106	10 / 160
1020-12	12	190	107	10 / 120
1020-13	13	206	135	10 / 120

KT NO.	Size mm	L mm		
1020-14	14	225	167	10 / 120
1020-15	15	225	193	6 / 72
1020-16	16	234	224	6 / 72
1020-17	17	234	237	4 / 48
1020-18	18	252	295	4 / 48
1020-19	19	250	290	4 / 48

## 1910

- Double end flexible head wrench with 12 points thin wall socket
- 180° swivel head for better accessibility
- Chrome vanadium alloy steel
- Chrome plated

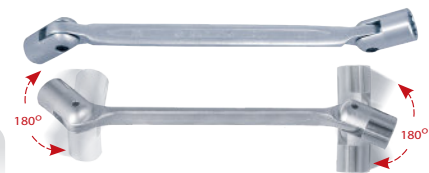
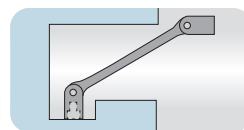
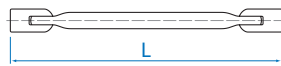

KT NO.	Size mm	L mm		
19100607	6 x 7	182	76	12 / 216
19100809	8 x 9	182	81	12 / 216
19100810	8 x 10	185	88	10 / 160
19101011	10 x 11	200	109	10 / 160
19101012	10 x 12	205	122	10 / 120
19101213	12 x 13	220	158	10 / 120
19101214	12 x 14	225	178	10 / 80
19101415	14 x 15	240	232	10 / 120
19101417	14 x 17	244	256	10 / 120
19101617	16 x 17	259	317	10 / 80

KT NO.	Size mm	L mm		
19101719	17 x 19	260	341	10 / 80
19101819	18 x 19	275	393	6 / 54
19101921	19 x 21	300	526	6 / 36
19102022	20 x 22	305	579	6 / 36
19102123	21 x 23	305	631	6 / 36
19102427	24 x 27	335	797	6 / 24

KT NO.	PC.	Contents		
1B06MR	6	1020 10, 12, 13, 14, 17, 19	1.06	1 / 24
1A06MR	6	1910 8 x 9, 10 x 11, 12 x 13, 14 x 15, 16 x 17, 18 x 19	1.49	1 / 16



► Nylon pouch bag



WRENCHES